

BY133 ... BY135

Silicon Rectifier Diodes – Silizium-Gleichrichterdioden

Version 2009-10-16

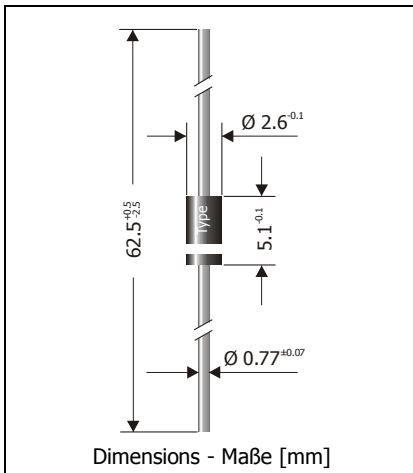

Nominal current Nennstrom	1 A
Repetitive peak reverse voltage Periodische Spitzensperrspannung	50...1300 V
Plastic case Kunststoffgehäuse	DO-41 DO-204AL
Weight approx. Gewicht ca.	0.4 g
Plastic material has UL classification 94V-0 Gehäusematerial UL94V-0 klassifiziert	
Standard packaging taped in ammo pack Standard Lieferform gegurtet in Ammo-Pack	



Maximum ratings

Grenzwerte

Type Typ	Repetitive peak reverse voltage Periodische Spitzensperrspannung V_{RRM} [V]	Surge peak reverse voltage Stoßspitzensperrspannung V_{RSM} [V] ¹⁾
BY133	1300	1600
BY134	600	800
BY135	150	200

Max. average forward rectified current, R-load Dauergrenzstrom in Einwegschaltung mit R-Last	$T_A = 50^\circ\text{C}$	I_{FAV}	1 A
Repetitive peak forward current Periodischer Spitzenstrom	$f > 15\text{ Hz}$	I_{FRM}	10 A ²⁾
Peak forward surge current, 50/60 Hz half sine-wave Stoßstrom für eine 50/60 Hz Sinus-Halbwelle	$T_A = 25^\circ\text{C}$	I_{FSM}	50/55 A
Rating for fusing, $t < 10\text{ ms}$ Grenzlastintegral, $t < 10\text{ ms}$	$T_A = 25^\circ\text{C}$	i^2t	12.5 A ² s
Junction temperature – Sperrschichttemperatur Storage temperature – Lagerungstemperatur		T_j T_s	-50...+175°C -50...+175°C

1 Tested with pulses $I_R = 100\ \mu\text{A}$, $t_p = 300\ \mu\text{s}$, duty cycle $\leq 2\%$

Gemessen mit Impulsen $I_R = 100\ \mu\text{A}$, $t_p = 300\ \mu\text{s}$, Schaltverhältnis $\leq 2\%$

2 Valid, if leads are kept at ambient temperature at a distance of 10 mm from case

Gültig, wenn die Anschlussdrähte in 10 mm Abstand vom Gehäuse auf Umgebungstemperatur gehalten werden

Characteristics

Kennwerte

Forward voltage – Durchlass-Spannung	$T_j = 25^\circ\text{C}$ $I_F = 1\text{ A}$	V_F	< 1.3 V
Leakage current Sperrstrom	$T_j = 25^\circ\text{C}$ $V_R = V_{RRM}$ $T_j = 100^\circ\text{C}$ $V_R = V_{RRM}$	I_R I_R	< 5 μA < 50 μA
Thermal resistance junction to ambient air Wärmewiderstand Sperrschicht – umgebende Luft		R_{thA}	< 45 K/W ¹⁾
Thermal resistance junction to terminal Wärmewiderstand Sperrschicht – Anschluss		R_{thT}	< 15 K/W

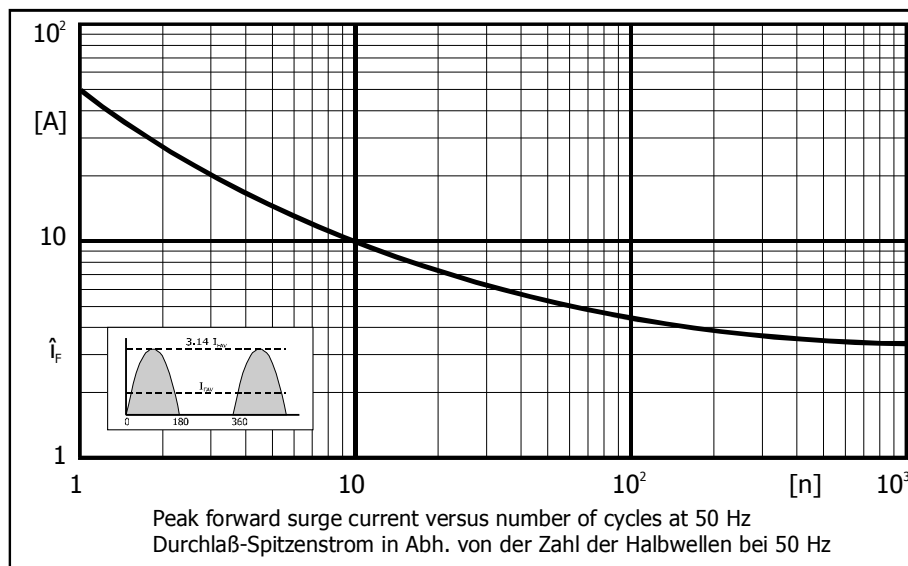
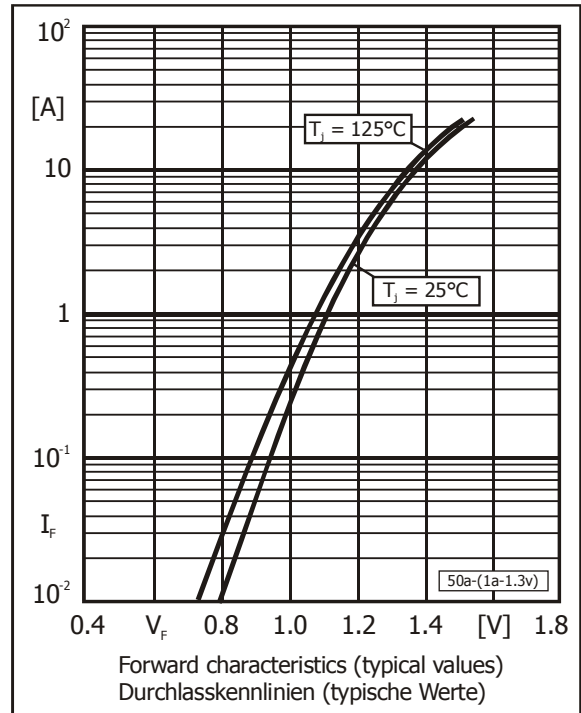
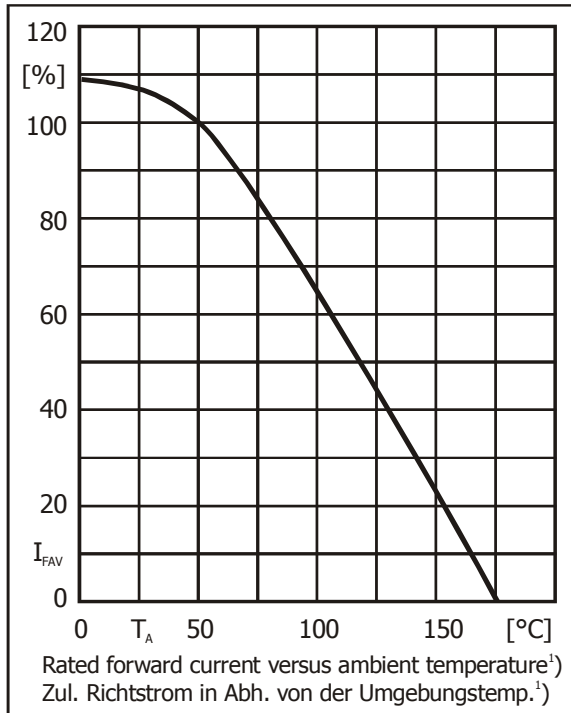

1 Valid, if leads are kept at ambient temperature at a distance of 10 mm from case
Gültig, wenn die Anschlussdrähte in 10 mm Abstand vom Gehäuse auf Umgebungstemperatur gehalten werden